

9/10/2014

Strategy Pattern

Bug Squashing Seminar
Matthias Eisenmann

dkfz.

GERMAN
CANCER RESEARCH CENTER
IN THE HELMHOLTZ ASSOCIATION



50 Years – Research for
A Life Without Cancer

What's the strategy pattern?

- General: A pattern is a way to document an elegant solution to a problem in a given context
- Intent of strategy pattern
 - Define a family of algorithms
 - Encapsulate each algorithm
 - Make algorithms interchangeable

Screenshot:
Packer Tool 7-Zip

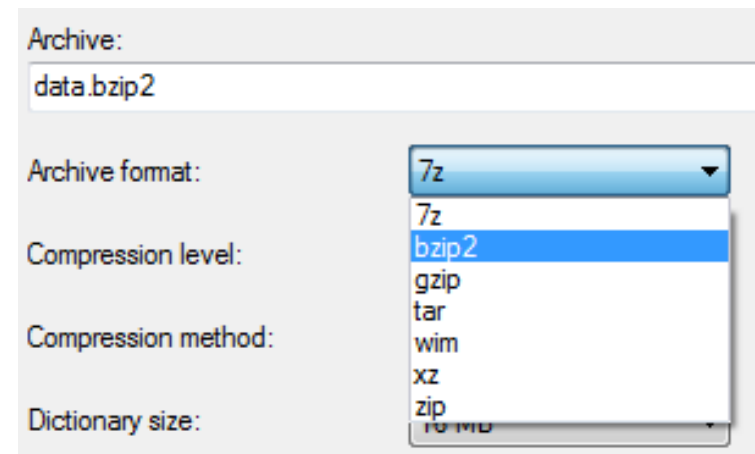

Structure (1)

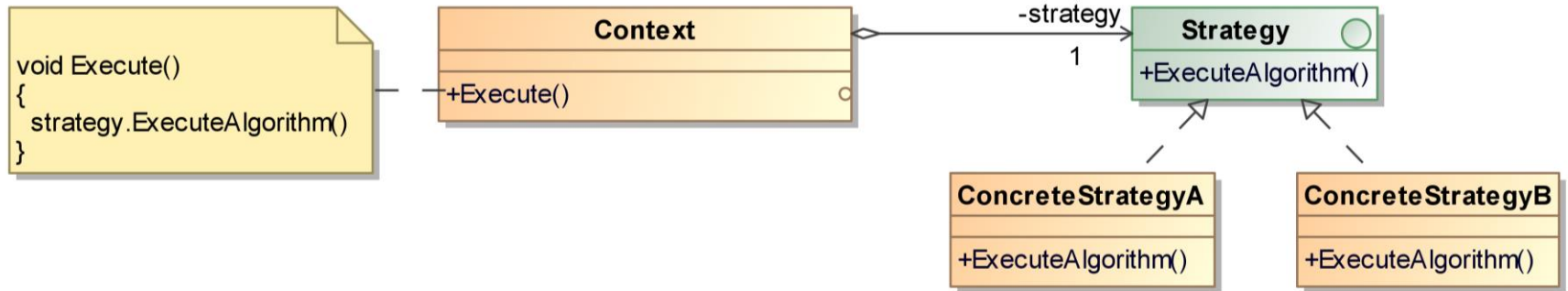

Structure (2)

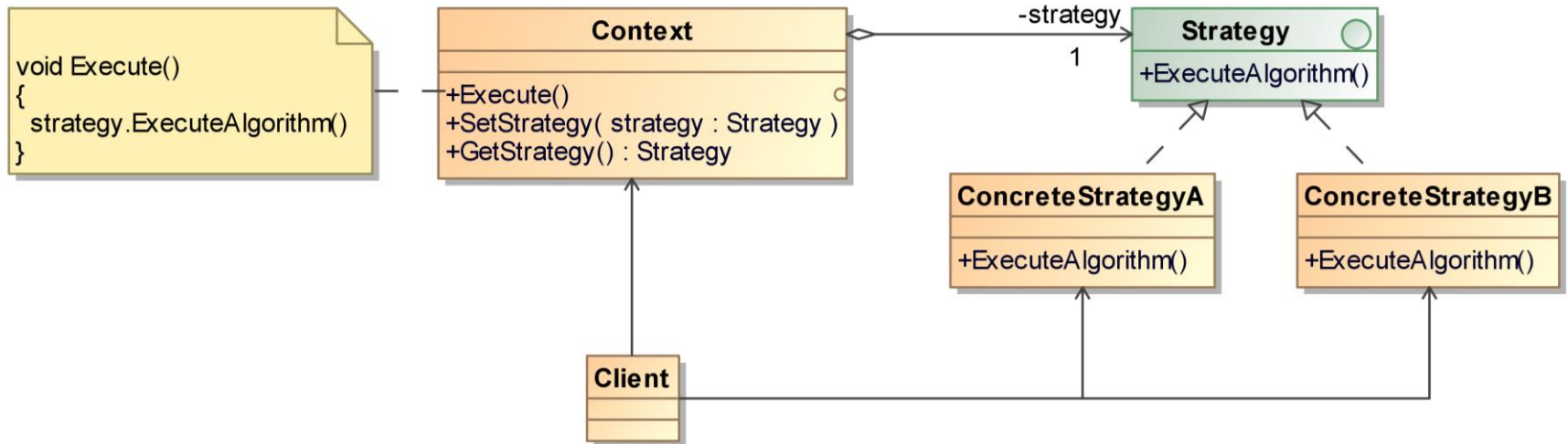

Applicability example

- Bad smell:
Conditional behavior depending on the type of an object

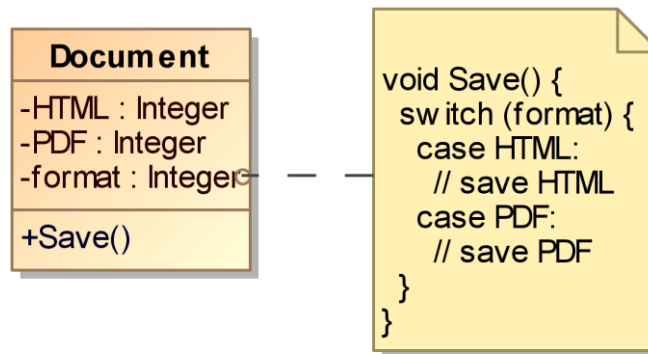

- Refactoring:

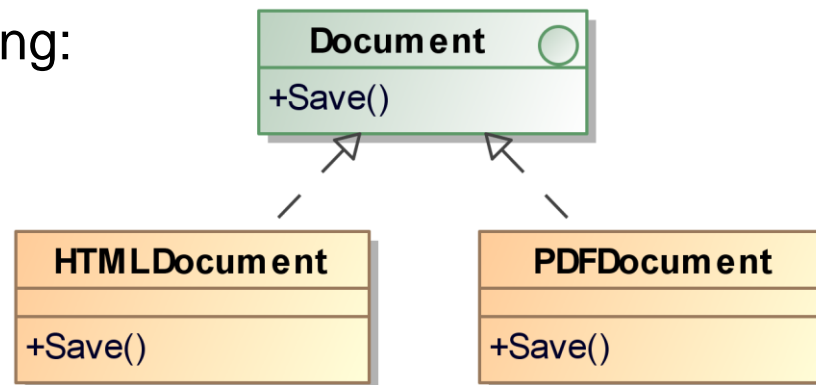

Summary

- Object behavioral pattern
- Design principles:
 - „Open/Close“, „One class one responsibility“
 - „Favor composition over inheritance“
- Pros
 - Obvious separation of context and strategy
 - Change/Add strategies without changing context
 - Increased reusability, separate tests possible
 - Selection of behavior at runtime
- Cons
 - Increased number of classes
 - Higher communication effort

Strategy pattern in MITK

- Examples:
 - FileReader
 - FileWriter

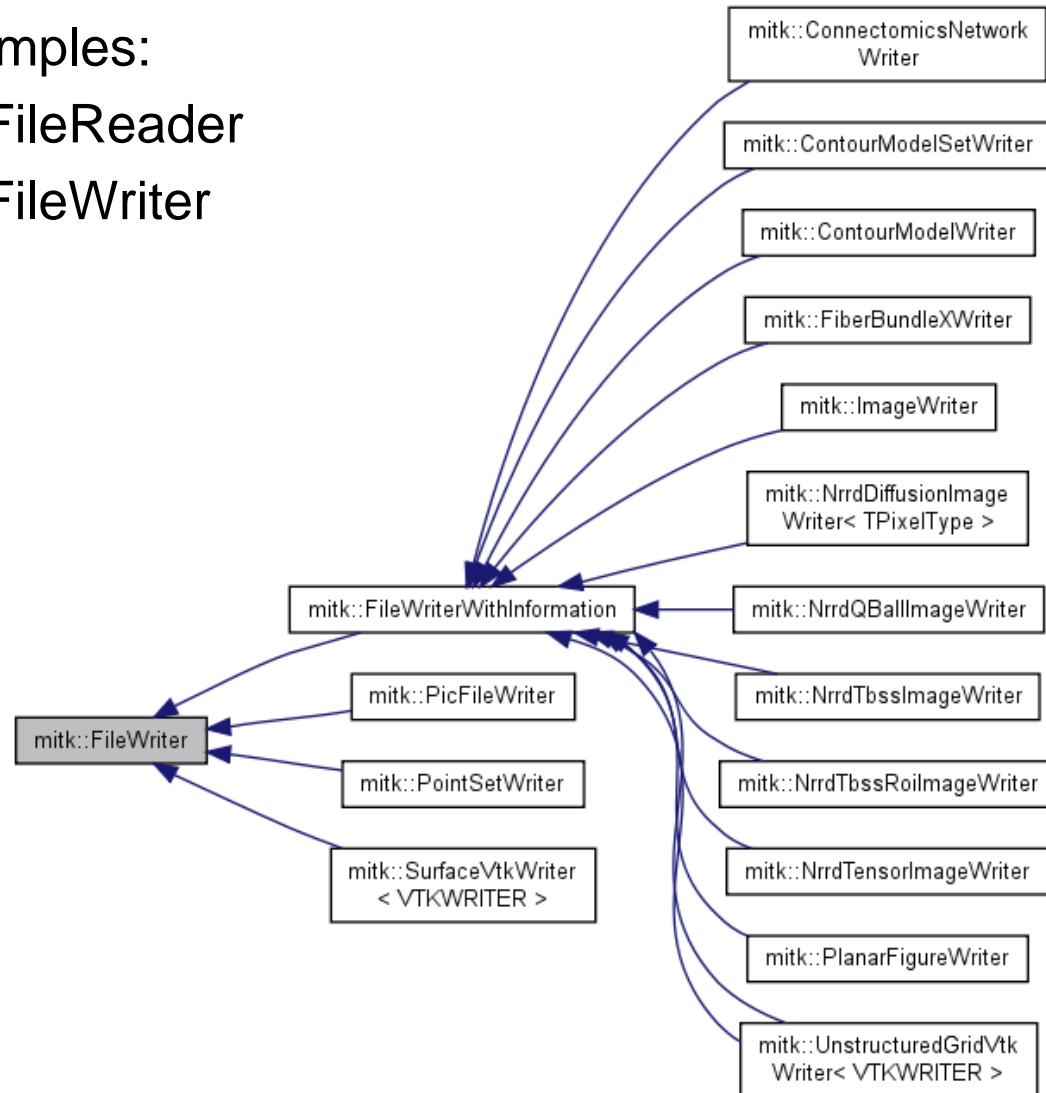

References

- Design Patterns. Elements of Reusable Object-Oriented Software, Erich Gamma, Richard Helm, Ralph Johnson, John Vlissides
- <http://www.philippbauer.de/study/se/design-pattern/strategy.php>
- http://docs.mitk.org/nightly-qt4/classmitk_1_1FileWriter.html

A photograph of the German Cancer Research Center (DKFZ) building, a modern multi-story structure with a central glass tower and balconies. In the foreground, there is a paved courtyard with several water fountains and orange benches. The sky is blue with some clouds.

Thank you
for your attention!

Further information on www.dkfz.de

dkfz.

GERMAN
CANCER RESEARCH CENTER
IN THE HELMHOLTZ ASSOCIATION



50 Years – Research for
A Life Without Cancer